



Things Worth Knowing about Hydraulic Cylinders

This chapter is intended to provide support for the design and choice of hydraulic cylinders.

It contains technical explanations and data, calculation formulae, practical information and references to the data sheets of the hydraulic cylinders in question.

In the data sheets, you will find further technical information and data.

1. Basic questions

- 1.1 How are hydraulic cylinders **built**?
- 1.2 What is the difference between **single-acting and double-acting** cylinders?

2. Calculations and more

- 2.1 How to calculate **push and pull forces**?
What is the **relationship** between **push and pull forces**?
Are there **losses of force**?
- 2.2 What is the necessary **piston diameter**?
How big are the **piston areas**?
- 2.3 How much **pressure** is necessary to generate a specific force?
- 2.4 What is the **maximum operating pressure** for a hydraulic system?
- 2.5 What is the **oil volume** required for the piston stroke?
- 2.6 How is the **stroke time** of a cylinder calculated?
- 2.7 How high is the **piston speed**?
- 2.8 What **pump flow rate** is obligatory with a preset stroke time?
- 2.9 Why is the **actual stroke time** often considerably longer than expected?
- 2.10 What volume is additionally required because of the **compressibility of the hydraulic oil**?
- 2.11 What volume is additionally required because of the **expansion of the material of high-pressure hoses**?
- 2.12 How does **the oil pressure change** in closed systems, when the **ambient temperature changes**?

3. Selection criteria

- 3.1 Which **operating temperatures** are possible?
When are **FKM seals** necessary?
- 3.2 Is the choice of **installation location** arbitrary?
What **fastening facilities** exist?
- 3.3 How are the moving **parts on the piston rod fastened**?
- 3.4 Which **hydraulic connection facilities** exist?
- 3.5 What must be taken into account when choosing the **hydraulic fluid**?

4. Hydraulic connector elements

- 4.1 Which **tube fittings** are used?
- 4.2 Which **hydraulic tubes** are used?
- 4.3 What has to be taken into account in the choice and use of **hydraulic hoses**?

5. General data and instructions

- 5.1 How much **oil leakage** occurs with hydraulic cylinders?
- 5.2 How great are the **dimensional tolerances**, when there is nothing listed on the data sheet?
What is the **dimensional tolerance** of the **housings**?
- 5.3 What must be taken into account **for safety**?
- 5.4 What support can I get for **assembly, start-up, maintenance and repairs** ?
- 5.5 What do the **graphic symbols in the hydraulic circuit diagram** mean?

6. Special requirements

- 6.1 Are **lateral piston forces** reliable or are there special designs?
- 6.2 Which **anti-torsion device** designs exist?
- 6.3 Which versions are available with **stroke end cushioning**?
- 6.4 What possibilities exist for **checking the piston position**?
- 6.5 Which **accessory parts** does ROEMHELD have in the range?
- 6.6 What are the **supply possibilities for stroke lengths not listed in the catalogue**?
- 6.7 The required **hydraulic cylinder is not listed in the catalogue** - are **special cylinders** available?

7. Further information

- 7.1 How do I get **CAD data** for the hydraulic cylinder?
Which **CAD formats** are available?
- 7.2 Who can answer any other **questions**?
- 7.3 Do I have the **latest edition of a catalogue sheet**?



1. Basic questions

1.1 How are hydraulic cylinders built?

Construction and term-labelling, using the example of a block cylinder

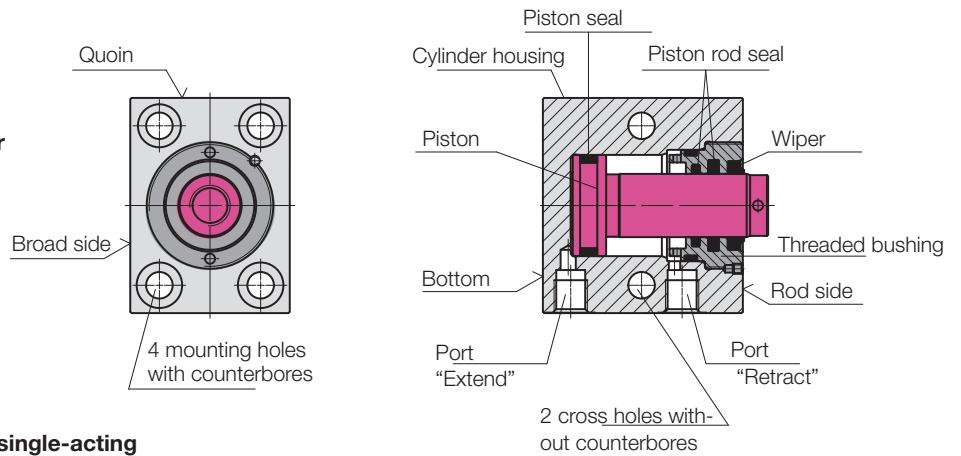

1.2 What is the difference between single-acting and double-acting cylinders?

Single-acting hydraulic cylinder (off-position)

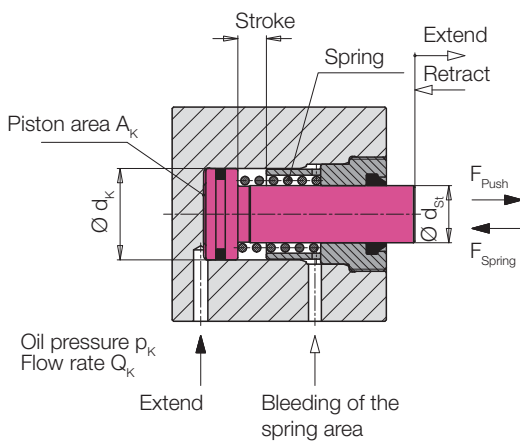

Double-acting hydraulic cylinder (off-position)

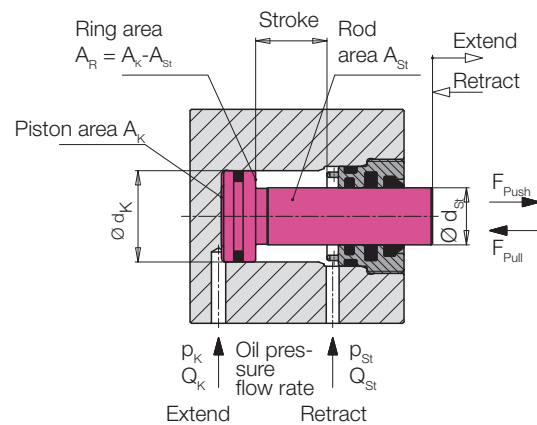

| Differentiated characteristics | Functioning | |
|--------------------------------|--|---|
| | single acting | double acting |
| Symbol | | |
| Force generation | in only one axial direction | in both axial directions |
| Retract/extend | in operating direction with hydraulic pressure, return with spring or external force | with hydraulic pressure on both sides |
| Return force | slight, mainly only slight spring forces | high, being hydraulic |
| Spring area | must be bled, ensuing risk of condensation water forming and penetration by corrosive liquids (see data sheet A 0.110 - Bleeding of Spring Area) | without |
| Times required for stroke | not precisely definable because of spring return strongly dependent on tube cross section and dependent on oil viscosity | precisely definable and with high repetitive accuracy |
| Functional reliability | failures possible, resulting from spring breaking | high functional reliability |



2. Calculations and more

2.1 How to calculate push und pull forces?

What is the relation between push and pull forces?

Are there losses of force?

If a hydraulic cylinder on the piston side is charged with the pressure p_K , it thus generates the

If a hydraulic cylinder on the piston rod side is charged with the pressure p_{St} , it thus produces the

Push force

$$F_{\text{Push}} \text{ [kN]} = \frac{p_K \text{ [bar]} * \pi * d_K^2 \text{ [cm}^2\text{]}}{400}$$

Pull force

$$F_{\text{Pull}} \text{ [kN]} = \frac{p_{St} \text{ [bar]} * \pi * (d_K^2 \text{ [cm}^2\text{]} - d_{St}^2 \text{ [cm}^2\text{]})}{400}$$

Conversions:

F force: 1 kN = 1000 N, 1 kN = 98.1 kp
 P pressure: 1 bar = 10^5 N/m² = 0.1 N/mm² = 0.1 MPa
 1 Pa = 1 N/m² (1 Pascal)
 π = 3,1416

Important!

The formulae only apply if there is no counterpressure ($p_{St} = 0$ or $p_K = 0$) or no counter force present. These opposing forces must, if necessary, be deducted from the push or pull force.

Push and pull force of the hydraulic cylinder

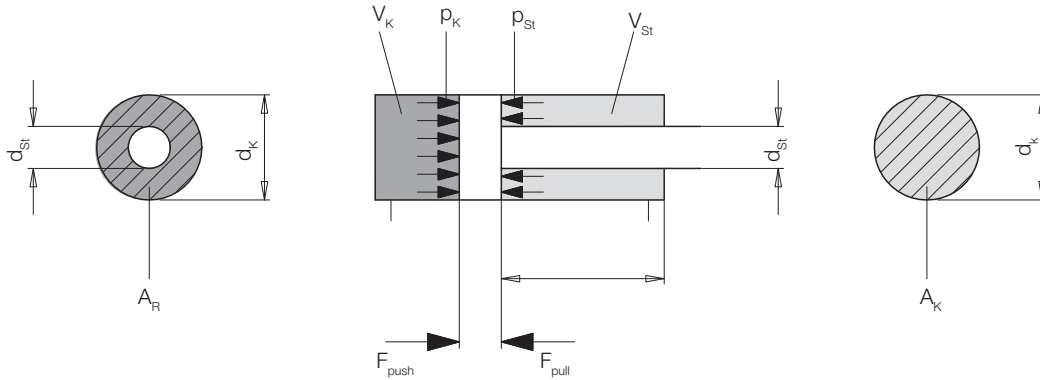

The relation between push and pull force in ROEMHELD hydraulic cylinders amounts approximately to:

$$F_{\text{Push}} \approx 1.6 * F_{\text{Pull}}$$

In order to obtain precise calculations of the force, any occurring losses of force or pressure must be taken into account.

| Loss of force/pressure by | Explanation |
|--|--|
| Piston and piston rod seals | The friction force of the seals has to be constantly overcome. Approximate value for loss of pressure on extending: 3 to 6 bar (The loss of pressure during the stroke is distinctly less) |
| Return spring | With single-acting cylinders with spring return, the cylinder force is reduced by the preload force of the return spring. |
| Losses of pressure in the hydraulic system | Flow resistances in pressure lines and valves reduce the pressure on the cylinder during motion |
| Impact pressure in the hydraulic system | When the oil cannot run off fast enough, in the return stroke, for example |

ROEMHELD supplies hydraulic cylinders with a push force up to 1570 kN.



2.2 What is the necessary piston diameter?

How big are the piston areas?

The minimum diameter of a piston, which is required for a necessary push force at a stipulated pressure, can be calculated as follows:

The next largest standardised piston diameter is selected.

Piston diameter

$$d_{\min} [\text{cm}] = \sqrt{\frac{F [\text{kN}] * 400}{\pi * p [\text{bar}]}}$$

The following graph shows the relation between oil pressure, piston force and piston diameter.

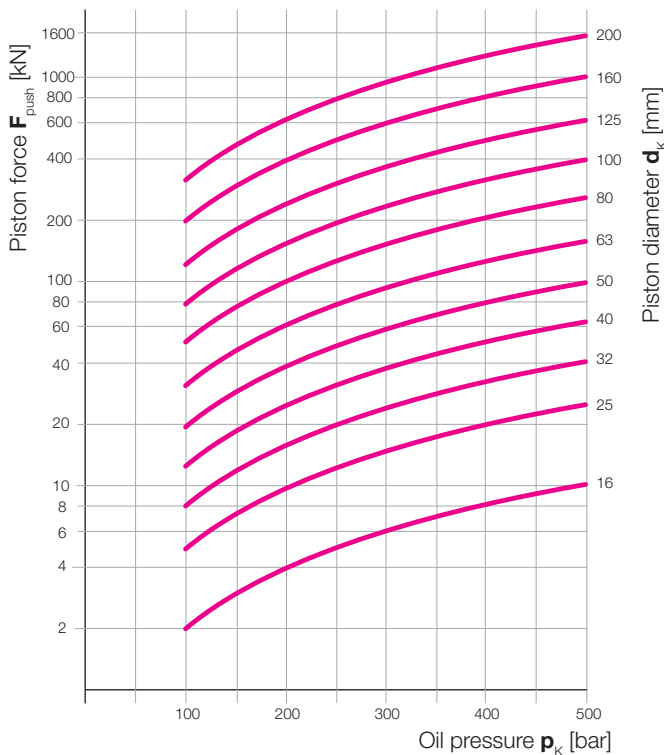

The piston areas can be calculated from the corresponding diameters:

Piston area

$$A_K [\text{cm}^2] = \frac{\pi}{4} * d_K^2 [\text{cm}^2]$$

Piston ring area

$$A_R [\text{cm}^2] = A_K - A_{St} [\text{cm}^2] = \frac{\pi}{4} * (d_K^2 - d_{St}^2) [\text{cm}^2]$$

There, A_{St} represents the

Piston ring area

$$A_{St} [\text{cm}^2] = \frac{\pi}{4} * d_{St}^2 [\text{cm}^2]$$

ROEMHELD supplies hydraulic cylinders for a wide range of piston diameters:

- double acting: Ø 16 mm to Ø 200 mm
- single acting: Ø 8 mm to Ø 100 mm

2.3 How much pressure is necessary to generate a specific force?

The necessary pressure can be calculated from the desired force and piston area:

Pressure

$$p [\text{bar}] = \frac{F [\text{kN}] * 100}{A [\text{cm}^2]}$$

2.4 What is the maximum operating pressure of a hydraulic system?

Every chain is only as strong as its weakest link. From that we can conclude that:

The maximum operating pressure in a hydraulic system is based on the part with the smallest acceptable maximum operating pressure.

Important!

All hydraulic elements such as valves, tubes, hoses, etc. must be adjusted to the maximum operating pressure for the system.

The following table gives an overview of the most important hydraulic cylinders and their maximum operating pressures:

| Hydraulic cylinders | Data sheet | Maximum operating pressure |
|--|------------|----------------------------|
| Block cylinders with steel housing | B 1.5094 | 500 bar |
| Block cylinders for stroke end control | B 1.520 | |
| RM mini slides | B 1.7384 | |
| Universal cylinders | B 1.309 | |
| Threaded-body cylinders | B 1.470 | |
| Block cylinders with bronze housing | B 1.553 | |
| Block cylinders with aluminium housing | B 1.554 | 350 bar |
| Block cylinders, protected against torsion | B 1.560 | |
| Hydraulic block cylinders | B 1.590 | 250 bar |
| RS hydraulic slides | B 1.7385 | |
| Hydro-cylinders | B 1.2811 | 200 bar |
| Hydro-cylinders | B 1.282 | |

Important!

The specified maximum operating pressure of hydraulic cylinders must never be exceeded - even briefly. This can lead to the destruction of the cylinder, with the possible consequences of considerable personal and material damage. In addition, it voids warranty claims, in any case.



2.5 What is the oil volume required for the piston stroke?

The oil volume **V** necessary for a piston stroke is calculated from the effective piston area **A** and from the required piston stroke.

Cylinder volume, general:

$$\mathbf{V [cm^3] = A [cm^2] * stroke [cm]}$$

Cylinder volume of the piston side V_K :

$$\mathbf{V_K [cm^3] = d_K^2 [cm^2] * \frac{\pi}{4} * stroke [cm]}$$

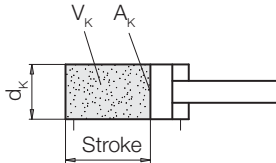

Cylinder volume of the piston rod side V_{St} :

$$\mathbf{V_{St} [cm^3] = (d_K^2 - d_{St}^2) [cm^2] * \frac{\pi}{4} * stroke [cm]}$$

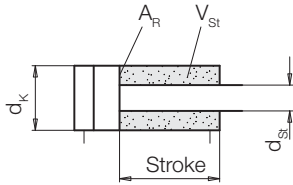

Stroke time for extending t_{HA} :

$$\mathbf{t_{HA} [s] = \frac{d_K^2 [cm^2] * \pi * stroke [cm]}{4 * Q [cm^3/s]}}$$

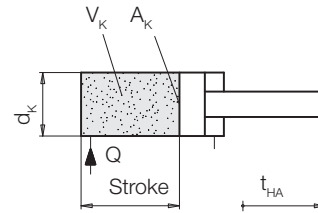

Stroke time for the retracting t_{HE} :

$$\mathbf{t_{HE} [s] = \frac{(d_K^2 - d_{St}^2) * \pi * stroke [cm]}{4 * Q [cm^3/s]}}$$

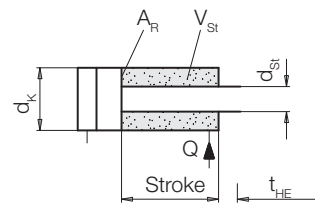

2.6 How is the stroke time of a cylinder calculated?

The stroke time for a piston stroke can be calculated from the cylinder volume **V** and the specified pump flow rate **Q**.

Stroke time

$$\mathbf{t_H [s] = \frac{V [cm^3]}{Q [cm^3/s]}}$$

or calculated from the piston area **A**:

Stroke time

$$\mathbf{t_H [s] = \frac{A [cm^2] * stroke [cm]}{Q [cm^3/s]}}$$

or calculated from the piston speed **v**:

Stroke time

$$\mathbf{t_H [s] = \frac{stroke [cm]}{v [cm/s]}}$$

Conversions:

Flow rate Q: 1 l/min = 16.667 cm³/s, 1 cm³/s = 0.06 l/min

Piston speed v: 1 m/s = 100 cm/s = 1000 mm/s

These purely mathematical time definitions are based on a constant piston speed throughout the entire stroke. Not considered here are acceleration times, times for switching operations or for pressure build up and similar.

2.7 How high is the piston speed?

At specified pump flow rate **Q** and with the effective piston area **A** the

Piston speed is calculated

$$\mathbf{v [cm/s] = \frac{Q [cm^3/s]}{A [cm^2]}}$$

or calculated by the stroke time t_H :

Piston speed

$$\mathbf{v [cm/s] = \frac{stroke [cm]}{t_H [cm^2]}}$$

Piston speed

on extending v_A :

$$\mathbf{v_A \left[\frac{cm}{s} \right] = \frac{Q [cm^3/s] * 4}{d_K^2 [cm^2] * \pi}}$$

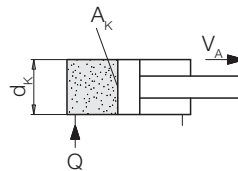

Piston speed

on retracting v_E :

$$\mathbf{v_E \left[\frac{cm}{s} \right] = \frac{Q [cm^3/s] * 4}{(d_K^2 - d_{St}^2) [cm^2] * \pi}}$$

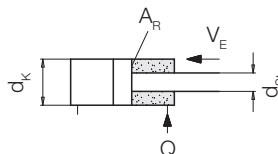

Important!

At the same pump flow rate **Q**, the piston speed on retracting is higher than on extending, by the area ratio ϕ .



The following applies to ROEMHELD hydraulic cylinders:

Area ratio:

$$\varphi = \frac{A_K}{A_R} \approx 1,6$$

The following results:

$$v_E = \varphi * v_A \approx 1.6 * v_A \quad (\text{when } Q=\text{constant})$$

The maximum permitted piston speeds must be observed for the hydraulic cylinders, in accordance with the following chart.

| Hydraulic cylinders | Data sheet | Maximum piston speed |
|--|------------|----------------------|
| Block cylinders with steel housing | B 1.5094 | 25 cm/s |
| RM mini slides | B 1.7384 | |
| Block cylinders with aluminium housing | B 1.554 | |
| Block cylinders with piston rod with exterior thread | B 1.542 | 50 cm/s |
| Hydro-cylinders | B 1.2811 | 50 cm/s |
| Hydro-cylinders | B 1.282 | |
| Hydraulic block cylinders | B 1.590 | |
| RS hydraulic slides | B 1.7335 | |

2.8 What pump flow rate is necessary with a preset stroke time?

The necessary pump flow rate is calculated from the total volume of all cylinders V_{ges} and from the time t_H , in which all strokes should be executed.

Required pump flow rate

$$Q_{erf} \left[\frac{cm^3}{s} \right] = \frac{V_{ges} [cm^3]}{t_H [s]} = \frac{V_1 + V_2 + \dots + V_n [cm^3]}{t_H [s]}$$

Important!

These calculations take into account only the pure stroke volumes of all cylinders in depressurised mode.

When the cycle time (time for the operating cycle) is stipulated and may not be exceeded by any means, the valve switch times must be observed, along with the acceleration times and the time for pressure build up until activation of the pressure switch, which signals the pressure reached (see Chapter 2.9).

Attention!

In practice, every desired cycle time is not always achieved. Especially when large masses are being moved and must not stop with too hard impact, the cylinders have to be choked again, which can cause the oil to heat considerably. In such cases, it is advisable to use hydraulic cylinders with stroke end cushioning.

2.9 Why is the actual stroke time often considerably longer than expected?

During the stroke motion, the hydraulic system is almost unpressurised, for the most part, since no great force or, consequently, pressure is necessary. Only when the piston hits the workpiece and the desired

force is to be produced, must the entire hydraulic system be pressurised. For this, the time t_{Dr} is necessary, as it can increase the calculated stroke time t_H considerably.

Actual stroke time

Actual stroke time t_{Ht} = stroke time t_H + time for pressure build up t_{Dr}

The reason for the time t_{Dr} is that the power unit has to pump an additional volume of oil into the hydraulic system. The most important reasons for this are as follows:

- compressibility of the hydraulic oil (see 2.10)
- increased volume of hydraulic hoses (see 2.11)

Thus, the power unit must actually provide the following volume:

Actual volume

| | | |
|---|--|------------|
| | Cylinder volume V | (see 2.5) |
| + | Volume for oil compressibility V_β | (see 2.10) |
| + | Volume increase of the hydraulic hoses V_{Szu} | (see 2.11) |
| = | Actual volume V_t | |

The

Actual stroke time results

$$t_{Ht} [s] = \frac{V_t [cm^3]}{Q [cm^3/s]}$$

Note!

To calculate the cycle time, it is, of course, necessary to determine the time for the return stroke in the same way.

In practice, it is not uncommon for the actual stroke time t_{Ht} to be 20% to 50% longer than the stroke time t_H .

2.10 What volume is additionally required because of the compressibility of the hydraulic oil?

If hydraulic oil is pressurised, then its volume decreases. That means that, in the case of a rise in pressure Δp (delta p), the power source must provide an additional volume V_β .

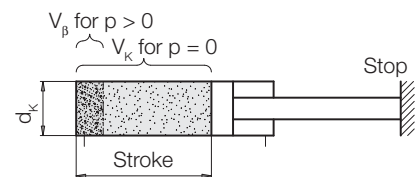

The volume V_β is calculated from the compressibility factor β of the hydraulic fluid.

Compressibility volume

$$V_\beta [cm^3] = V_{ges} [cm^3] * \beta [1/bar] * \Delta p [bar]$$

For hydraulic oil, β amounts to approx. $70 * 10^{-6} 1/bar$.

This means:

For a pressure increase of 100 bar, 0.7 % more oil volume is required.



In calculating V_{β} of a hydraulic system, the total oil volume V_{ges} which is compressed must be taken into account. That means that all oil volumes must be added, from the pressure source through to the hydraulic cylinders.

Total volume

| | | | |
|---|-------------------------------|-----------|-----------|
| | Volume of the hydraulic tubes | V_R | |
| + | Volume of the hydraulic hoses | V_S | |
| + | Cylinder volume | V | (see 2.5) |
| = | Total volume | V_{ges} | |

Important!

Air in the hydraulic oil increases the compressibility and the additional volume V_{β} . This causes a considerable increase in the actual stroke time t_{ht} . That is why each hydraulic system must be bled carefully during start-up.

2.11 What volume is additionally required because of the expansion of the material of high-pressure hoses?

When the hoses are charged with pressure, they expand and take in an additional volume of hydraulic oil. Since it is relatively large, this volume should be taken into consideration for calculating the actual stroke time t_{ht} .

The increase in volume of the hydraulic hoses V_{Szu} is calculated from the specific increase in volume dependent on the nominal diameter V_{Sp} .

Approximate values for the specific increase in volume V_{Sp} :

| Hose nominal diameter ND [mm] | Specific increase in volume $V_{Sp} \left[\frac{cm^3}{m \cdot bar} \right]$ |
|-------------------------------|--|
| 6 | 0,01 |
| 10 | 0,015 |
| 13 | 0,025 |
| 16 | 0,035 |
| 20 | 0,05 |

With specified hose length L_s and pressure increase Δp , the following results:

Increase in volume of hydraulic hoses

$$V_{Szu} = V_{Sp} \left[\frac{cm^3}{m \cdot bar} \right] * L_s [m] * \Delta p [bar]$$

It follows from the above formula:

With a nominal diameter of ND 6, a pressure increase of 100 bar and a hose length of 1 m, a hydraulic hose increases in volume by 1 cm³.

Note!

The increase in volume of hydraulic tubes may generally be disregarded.

2.12 How does the oil pressure change in closed systems, when the ambient temperature changes?

All hydraulic fluids expand with an increase in temperature.

The difference in volume V_T , caused by a difference in temperature ΔT , is calculated by the heat expansion factor α of the hydraulic fluid.

Difference in volume resulting from a change in temperature

$$V_T [cm^3] = V [cm^3] * \alpha [1/K] * \Delta T [K]$$

[K]: Kelvin Scale (20 °C is 293 K)

For hydraulic oil, α amounts to approx. $0.67 \cdot 10^{-3} 1/K$

Note!

The difference in temperature may be inserted in the formula in the Kelvin [K] or Celsius [°C] Scale.

According to the above formula, the following applies to hydraulic oil:

A rise in temperature of 15°C produces an increase in volume of approx. 1%.

In a closed hydraulic system, however, there is no available space for volume expansion. The hydraulic fluid is compressed according to the compressibility factor β (see 2.10) and this results in a pressure increase Δp , in accordance with the following formula:

Pressure increase

$$\Delta p [bar] = \frac{\alpha [1/K]}{\beta [1/bar]} * \Delta T [K]$$

With the approximate values for α and β , the results for hydraulic oil are as follows:

Pressure increase

$$\Delta p [bar] = 9.571 * \Delta T [K]$$

The following applies to hydraulic oil:

A temperature increase of 1°C causes an increase in pressure of around 10 bar.

In a closed hydraulic system, it is necessary - depending on the application - to take into account the change in pressure resulting from a change in temperature, as early as the planning stage.

Unacceptable pressure increases can, for example, be avoided by pressure relief valves.

Unwanted pressure loss can be reduced by a pressure accumulator.

3. Selection criteria

3.1 Which operating temperatures are possible? When are FKM seals required?

The temperature range in which the hydraulic cylinders can be used depends, firstly, on the sealing material used. Normally, the O-rings used determine the temperature ranges. ROEMHELD hydraulic cylinders are fitted with the following sealing materials as standard:

NBR : -30 °C to +100 °C

NBR = nitrile-butadiene rubber, Trade name e.g.: Perbunan

FKM : -20 °C to +150 °C

FKM = fluor caoutchouc, Trade name e.g.: VITON®

The data relate to the direct temperatures of the seals, which can be calculated from the ambient temperature and the temperature of the hydraulic fluid at the actual operating temperature of the hydraulic cylinder. That means, for example, that the internal temperature of an injected mould can be much higher than the operating temperature of a hydraulic cylinder fitted to the mould.

Hydraulic cylinders for operating temperatures of 150 °C up to 200 °C

Can be supplied as a special version.

This is a case of a FKM version with special back-up rings.



Hydraulic cylinders for operating temperatures in excess of 200 °C

If operating temperatures in excess of 200 °C are required, design-engineering measures (insulation, cooling or similar) should be adopted from the outset, to reduce the operating temperature of the hydraulic cylinder.

Indeed, seal manufacturerers also supply O-rings for higher temperatures (e.g. from FKM Perfluor rubber with the brand names of Kalrez, Isolast etc.) but these are mainly not suited to the dynamic sealing requirements of a hydraulic cylinder. In addition, the seal manufacturerers do not usually supply wiper rings in those materials.

In choosing a hydraulic cylinder, the following must also be taken into account, regarding the operating temperature:

- choice of a suitable hydraulic fluid
- admissible operating temperature of fitted accessory parts (e.g. position controls)
- admissible operating temperature of accessory parts fitted directly inside the cylinder (e.g. the magnet for hydraulic cylinders with position controls by magnetic sensors)

3.2 Is the choice of installation position arbitrary? What fastening facilities exist?

ROEMHELD hydraulic cylinders can be installed in any position.

To fasten the cylinders, there are mainly through holes available for bolts in accordance with DIN ISO 273, lengthwise and/or across the cylinder axis. Several cylinder series are also provided with counterbores for hexagon sockets head cap screws as per DIN 912.

Counterbores for through holes

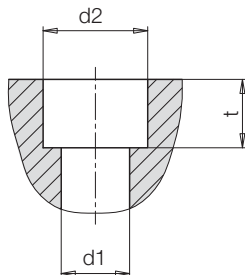

If other specifications are not included in the data sheet, ROEMHELD hydraulic cylinders are given the following counterbores:

| Socket head cap screw DIN 912 / thread | Dimensions | | | |
|---|--------------|--------------|------------------------------|----------------------------|
| | Ø d1 [mm] | Ø d2 [mm] | t (at the bottom) [mm] | t (on rod side) [mm] |
| M6 | 6,5 | 11,0 | 5,0 | 7,0 |
| M8 | 8,5 | 13,5 | 9,0 | 9,0 |
| M10 | 10,5 | 17,0 | 11,0 | 11,0 |
| M12 | 13,0 | 20,0 | 13,0 | 13,0 |
| M16 | 17,0 | 26,0 | 17,0 | 17,0 |
| M20 | 21,0 | 33,0 | 21,5 | 21,5 |
| M24 | 25,0 | 40,0 | 25,5 | 25,5 |
| M30 | 32,0 | 48,0 | 32,0 | 32,0 |
| M36 | 39,0 | 57,0 | 38,0 | 38,0 |
| M48 | 52,0 | 76,0 | 50,0 | 50,0 |

Because of their great length, block cylinders with longer strokes (160 and 200 mm) have internal threads for fastening, as standard, instead of the lengthwise mounting holes.

For shorter strokes, the version “thread instead of lengthwise mounting holes” is supplied at a higher price (see current price list), as a variant of the standard cylinder.

4 tapped blind holes each are inserted at the bottom and at the rod side. There are no lengthwise mounting holes.

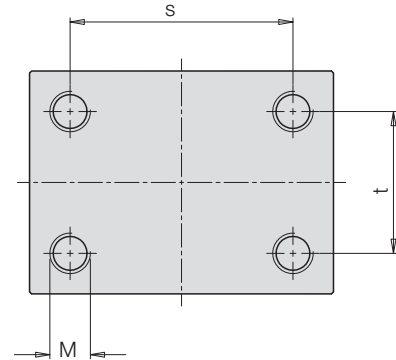

As a variant, the following internal threads are supplied:

| Internal thread dimensions | | | | |
|----------------------------|---------------|--------------------|-----------|-----------|
| Piston Ø [mm] | Rod Ø [mm] | max. depth [mm] | s [mm] | t [mm] |
| 16 | 10 | M6x9 | 40 | 22 |
| 25 | 16 | M8x12 | 50 | 30 |
| 32 | 20 | M10x15 | 55 | 35 |
| 40 | 25 | M10x15 | 63 | 40 |
| 50 | 32 | M12x18 | 76 | 45 |
| 63 | 40 | M16x24 | 95 | 65 |
| 80 | 50 | M20x30 | 120 | 80 |
| 100 | 60 | M24x36 | 158 | 108 |
| 125 | 80 | M30x45 | 180 | 130 |
| 160 | 100 | M36x54 | 230 | 160 |
| 200 | 125 | M50x75 | 300 | 220 |

Applicable to data sheets B 1.5094, B 1.542, B 1.552 and B 1.554. Other dimensions and lines on request.

Note!

In principle, screws of tensile strength 8.8 can be used to secure the cylinders.

If hydraulic cylinders are fastened with screws across the cylinder axis, the screws are stressed to the point of shearing by the cylinder forces. In this case, hydraulic cylinders above a specific operating pressure must be supported.

Block cylinders with rear support

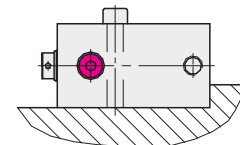

The support only has to be a few millimetres high.

The support must counter the force generated. That means that there must be support behind (at the bottom) when they are used as pressure cylinders (for generating push force). When used as pull-type cylinders (for pull force), they must be supported in front (on the rod side).



Support is obligatory at and above the following operating pressures:

| Cylinders | Data sheet | Push-type cylinders | Pull-type cylinders |
|---------------------------|----------------|---------------------|---------------------|
| Block cylinders | B 1.5094, etc. | from 160 bar | from 250 bar |
| Hydraulic block cylinders | B 1.590 | from 100 bar | from 160 bar |

As an alternative to this support, hydraulic cylinders can be fitted in the housing with a keyway, which transfers the cylinder forces to the baseplate surface via a key. The support described above then becomes superfluous.

The following hydraulic cylinders already have a keyway fitted as standard:

- Hydraulic block cylinders B 1.590
- RS hydraulic slides B 1.7385

For block cylinders, the version “with extra keyway” is supplied at a higher price (see current price list), as a variant of the standard cylinder.

This variant comprises a specific keyway in the following position and with the following dimensions:

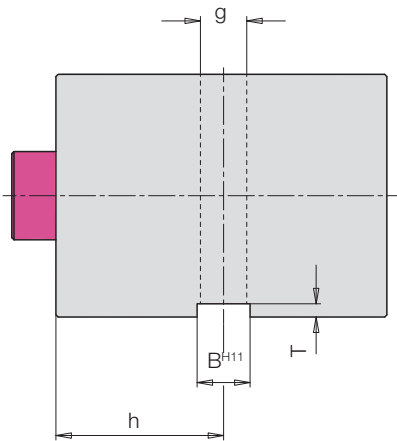

Keyway dimensions

| Piston/rod Ø [mm] | Slot width B ^{H11} [mm] | Slot depth T [mm] | Slot location h [mm] | Dia. g [mm] |
|-------------------|----------------------------------|-------------------|----------------------|-------------|
| 16/10 | 8 | 2 | 30 | 6,5 |
| 25/16 | 10 | 2 | 33 | 8,5 |
| 32/20 | 12 | 3 | 38 | 10,5 |
| 40/25 | 12 | 3 | 40 | 10,5 |
| 50/32 | 15 | 5 | 44 | 13 |
| 63/40 | 20 | 5 | 50 | 17 |
| 80/50 | 24 | 7 | 60 | 21 |
| 100/60 | 28 | 7 | 64 | 25 |
| 125/80 | 35 | 7 | 82 | 32 |
| 160/100 | 42 | 9 | 92 | 39 |
| 200/125 | 55 | 9 | 112 | 52 |

Applicable to data sheets B 1.5094, B 1.542, B 1.552 and B 1.554. Other dimensions and lines on request.

The following hydraulic cylinders present an alternative to the fastening:

- **Universal cylinders with external thread** (data sheet B 1.309)

The round housing with external thread can be easily fastened, with two lock nuts in through holes. The cylinder can be precisely positioned in through holes, in the axial direction with the lock nuts.

- **Universal cylinders with spherical bearing joint** (data sheet B 1.542 / G 3.810)

A spherical bearing joint is directly fastened to the block cylinder housing and it can take a suitable bearing pin. As an option, a spherical bearing eye is obtainable for screwing onto the piston rod.

3.3 How are the moving parts on the piston rod fastened?

To fasten parts to the piston rod, most hydraulic cylinders are fitted with an internal thread in it.

Piston rod with internal thread

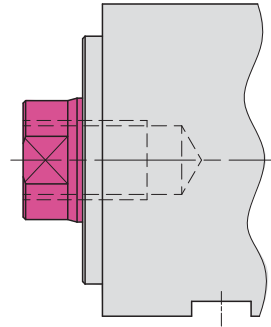

As an arrester for tightening the parts, the hydraulic cylinders either have two milled wrench flats on the piston rod (for small diameters) or radial holes in the piston rod (for large diameters).

The customer can also insert set screws in the internal threads to make a connector for external threads. In that case, care must be taken to ensure that the set screw can transfer the forces generated.

Piston rod with internal thread and set screw

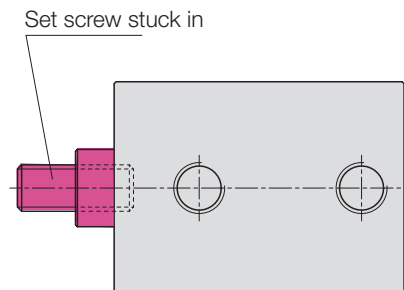

As an alternative to the internal thread, ROEMHELD supplies the following versions which have a piston rod with external thread:

- B 1.542 - Block cylinder and piston rod with external thread
 - Block cylinders with spherical bearing joint
- B 1.590 - Hydraulic block cylinders

Piston rod with external thread

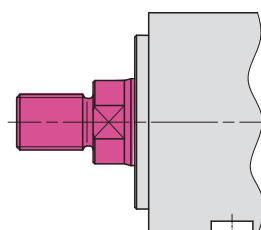



For fastening components which are also guided, contact bolts with coupling pins (see data sheet G 3.800) have to be used, to avoid forced conditions.

Piston rod with interior thread and contact bolts with coupling pins

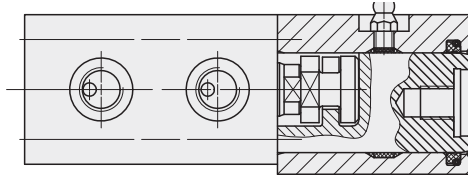

Exceptions are RM mini slides (data sheet B 1.7384) and RS hydraulic slides (data sheet B 1.7385), for which a complete steel plate is provided for fastening mounted parts.

RS hydraulic slides with front block

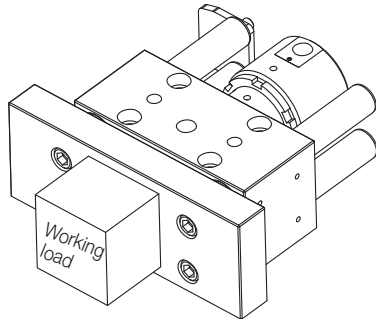

3.4 Which hydraulic connection facilities exist?

Irrespective of the design, hydraulic cylinders have two different possibilities for the hydraulic connection.

Tube thread G

The cylinder has Whitworth connecting threads as per DIN ISO 228 (short symbol G) with screw hole as per DIN 3852 sheet 2 (for cylindrical screwed plugs); with block cylinders, they are generally located on the quoin.

The hydraulic connection is effected by suitable tube fittings.

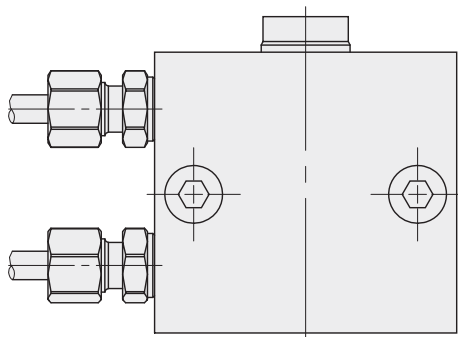

Designs for manifold mounting with O-ring sealing

The cylinder is manifold-mounted onto a base plate or similar and receives the hydraulic fluid through drilled hydraulic channels O-rings, with counterbores in the hydraulic cylinder, seal the gap between cylinder and baseplate. The O-rings required for sealing are always supplied with the hydraulic cylinder.

So that a perfect seal is guaranteed, the baseplate manifold-mounting area must have a raw surface depth of $Ra < 0.8$. The connector hole in the baseplate must not be bigger than the corresponding hole in the cylinder.

Dependent on the location of the oil supply, the following versions exist:

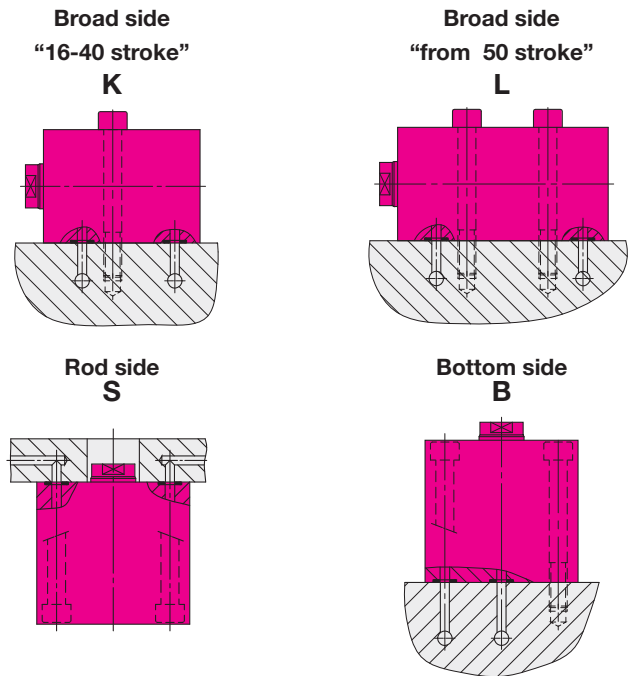

Note!

Versions K and L must be fastened by means of the cross holes and therefore do not have lengthwise mounting holes. Versions B and S must be fastened by means of the lengthwise mounting holes and therefore do not have cross holes.

3.5 What must be taken into account when choosing the hydraulic fluid?

When choosing the hydraulic fluid, in addition to the hydraulic cylinder you must take into consideration all other components of the hydraulic system (e.g. pumps, valves etc.) and their combined effects (e.g. heat production). The following criteria apply:

- temperature/viscosity behaviour
- wear or corrosion behaviour/material resistance
- combustibility or flammability
- environmental compatibility
- resistance to ageing

When choosing a hydraulic fluid, you should consult the manufacturer, if in doubt. That is because even small quantities of additives from the manufacturer can affect the properties of the hydraulic fluid.

Irrespective of the type chosen, the hydraulic fluid should be checked regularly (contamination, oil level, etc.) and changed (depending on operating hours, type, etc.).

It goes without saying that the relevant safety data sheet should always be present.

The table below gives an overview of the individual groups of hydraulic fluids.



Hydraulic fluids - Overview

| Hydraulic fluid | Description | Remarks |
|--|---|---|
| Mineral oils | | |
| - HL hydraulic oils (DIN 51524 Part 1) | Mineral oil for corrosion protection and ageing stability | For highly stressed hydraulic elements not suitable because of a lack of antiwear additives |
| - HLP hydraulic oils (DIN 51524 Part 2) | Mineral oil like HL but with added antiwear protection | Commonly used mineral oil, recommended in the Viscosity classes: HLP 22 for oil temperature of 10..40°C (Power workholding) HLP 32 for oil temperature of 15..50°C HLP 46 for oil temperature of 20..60°C (continuous operation) |
| - HLPV hydraulic oils (DIN 51524 Teil 3) | Mineral oil like HL but with increased, viscosity index for use in a wide temperature range | Also detrimental effects on the viscosity under pressure |
| - unalloyed H oils - e.g., lube oils (DIN 51517 Part 1) | Mineral oil without additives | Low lubricity |
| - other mineral oils - e.g. motor oils, transmission oils | Mineral oils, which for other applications have been developed | Mainly less suited |
| - special oils according to, for example, MIL or NATO standard | Mineral oils mainly for the military field have been developed | Pay particular attention to material resistance |

Highly inflammable hydraulic fluids as per DIN 51502

| | | |
|---------|--|--|
| - HFA | Oil-in-water emulsion (water component > 80%) | Less suited because of corrosion caused by the of high water component - max. operating pressure approx. 150 bar - max. temperature approx. 60°C |
| - HFB | Water-in-oil emulsion (water component > 40%) | Less suited because of corrosion caused by the of high water component - max. operating pressure approx. 200 bar - max. temperature approx. 60°C |
| - HFC | Aqueous polyglycol solution (water and glycol) (water component < 35%) | Highly suitable (with NBR- or FKM seals) - max. operating pressure approx. 200 bar - max. temperature approx. 60°C |
| - HFD | Anhydrous liquid with similar properties as mineral oil | Only highly suitable with FKM seals - max. operating pressure approx. 500 bar - max. temperature approx. 150°C |
| - HFD-R | - phosphoric acid ester | |
| - HFD-S | - chlorinated hydrocarbons | |
| - HFD-T | - blend of HFD-R and HFD-S | |
| - HFD-U | - based on other compounds | |

Environmentally friendly hydraulic fluids

| | | |
|---|---|---|
| - HETG native oils - e.g. rape oil, sunflower oil | Liquids based on natural oils | Very low suitability, at high temperatures tend towards stickiness and premature ageing |
| - HEPG polyethylene glycol | Liquids based on polyethylene glycol (PAG) with similar properties as mineral oil | Generally suitable but testing necessary in individual cases |
| - HEES synthetic ester - polyester - diester - carbonic acid ester | Liquids based on synthetic manufactured esters | Generally suitable |

Special fluids

| | | |
|----------------|----------------------------------|--|
| - brake fluids | Glycol-based brake fluids (DOT4) | Use possible only with EPDM, not with seals made of NBR or FKM |
|----------------|----------------------------------|--|



4. Hydraulic connector elements

4.1 Which tube fittings are used?

Fittings suitable for the Whitworth G tube thread correspond to DIN 2353, screwed plug type B according to DIN 3852 Sheet 2.

Metallically sealing versions (with knife edge) are used as tube fittings for hydraulic cylinders with steel housings. Only fittings with soft seals (elastic seals) must be used for hydraulic cylinders with aluminium housings.

Important!

No additional sealing materials, such as Teflon ribbon, must be used!

There are two series of tube fittings:

- **Series L:** "light series" for maximum operating pressure of 250..350 bar (depending on the version)
- **Series S:** "heavy series" for maximum operating pressure of 400..500 bar (depending on the version)

Series L have slightly smaller dimensions, compared with Series S.

You will find tube fittings on data sheet F 9.300.

4.2 Which hydraulic tubes are used?

As a connecting piece, we recommend that you use seamless, galvanized hydraulic tube, made of St 37, as per DIN 2391 (which you will find on data sheet F 9.300).

The necessary tube wall thickness is based on the nominal pressure, as the following table shows.

Recommended tube wall thickness in [mm]

| Nominal pressure PN [bar] | Tube exterior Ø [mm] | | | | |
|------------------------------|----------------------|-----|-----|-----|-----|
| | 6 | 8 | 10 | 12 | 15 |
| 100 | 1,0 | 1,0 | 1,0 | 1,0 | 1,0 |
| 160 | 1,0 | 1,0 | 1,0 | 1,0 | 1,0 |
| 250 | 1,0 | 1,0 | 1,5 | 1,5 | 1,5 |
| 320 | 1,0 | 1,0 | 1,5 | 1,5 | 2,0 |
| 400 | 1,0 | 1,5 | 2,0 | 2,0 | 2,5 |
| 500 | 1,5 | 2,0 | 2,5 | 2,5 | 3,0 |

In order to keep down dynamic losses of pressure in tubes, tubes should be as short as possible and designed with large bending radii.

4.3 What has to be taken into consideration in the choice and use of hydraulic hoses?

Hydraulic high-pressure hoses, with four-fold security to prevent bursts, should be used as connector hoses. You will find these on data sheet F 9.361, as pre-assembled hoses equipped with fittings. In addition to the four preferred lengths, lengths are also supplied to customer requirements.

In using hydraulic hoses, particular attention should be paid to certain criteria.

Fluid

There must be resistance to the fluids used. The high-pressure hoses on data sheet F 9.361 are resistant to all mineral-oil based hydraulic oils and to water glycols.

Maximum operating pressure

Hoses are normally subject to dynamic stress. Acceleration and delay processes cause pressure spikes which may be well above the static pressure. The maximum operating pressure is therefore differentiated and specified for tumescent and intermittent operation.

Increase in volume caused by stretching of material

When the hoses are charged with pressure, they stretch and take in an additional volume of hydraulic fluid. This volume can be disregarded for most applications but it is essential to observe it for applications with a short cycle time (see 2.9).

Bending radius

It is essential to observe the specified minimum bending radii. The bending radius directly affects the hose length and is calculated as follows.

Static use

$$\text{Length} = 2A + 3,142 \times R = 2A + X$$

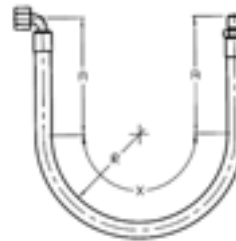

Flexible use

$$\text{Length} = 2A + 3,142 \times R + T = 2A + X + T$$

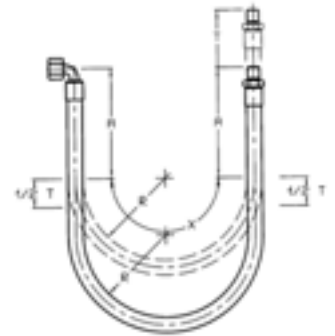

In order to avoid buckling at the fittings, both ends of the hose must be aligned straight. That is why we recommend that you proceed according to the illustrations above, in which "R" is the minimum bending radius, in calculating the length. This radius is measured on the inside of the bend, whereby the hose must not flatten by more than 10% of the original external diameter.

In calculating flexibly installed tubes, the length "T", corresponding to the length of stroke, must be taken into account.

The minimum length behind the fittings A is based on the following chart:

| Nominal hose diameter ND [mm] | 6 | 8 | 10 | 12 | 16 |
|-------------------------------|-----|-----|-----|-----|-----|
| Minimum length A [mm] | 100 | 110 | 120 | 130 | 140 |

For every complete tube, the dimension "A" must be taken into account twice; the dimension "A" increases by 50% for elbow fittings!

Note!

Since tubes are generally designed with at least one bend, it is essential to avoid tensile stress on the fittings, in order to guarantee the greatest possible duration of use.



Fitting

The following notes show the things to heed when fitting hoses.

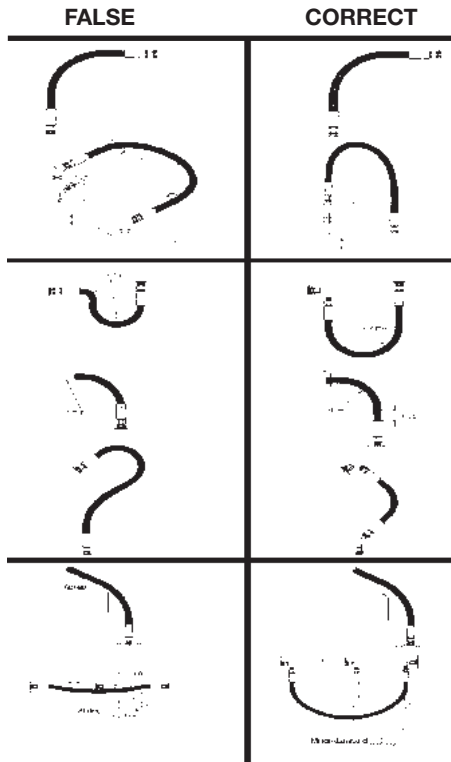

Avoid twisting tubes. Where moving parts can cause a twist in the tube, avoid this by fitting the tube correctly.

By using the correct fittings, you avoid bending radii which are too small. Under no circumstances should you bend closer than 1.5 x "d" after fitting!

Avoid contact with objects which can cause abrasion or damage. If the hose is intended to move while in use, pay particular attention to the length.

Nomogram to determine the hose diameter ND

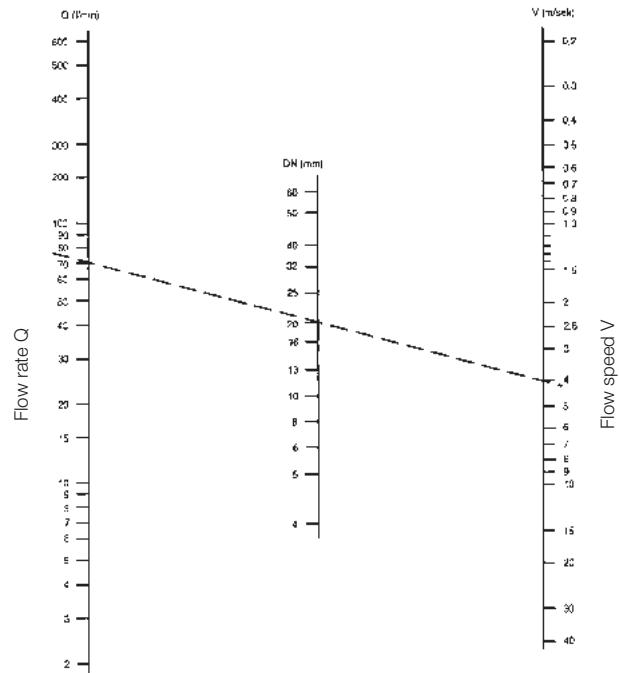

By linking the two values for **Q** (l/min) and **V** (m/s), on the centre chart, we get the nominal hose value **ND**. The next highest standardised diameter should then be chosen.

Example:

| | | |
|----------------|---------------------------------|----------|
| Given: | Flow rate Q : | 70 l/min |
| Given: | Flow speed V : | 4 m/s |
| From nomogram: | Nominal diameter (ND): | 20 mm |

Reference values for maximal flow speeds of hydraulic hoses are:

- Pressure lines: 5 m/s
- Return lines: 2 m/s
- Suction lines: 1.2 m/s

Note!

The maximal permitted flow speed for hydraulic cylinders (see 2.6) is well below the maximum flow speed for hydraulic hoses.

Wear / ageing

Hoses must be classified as wearing parts, since they are subject to natural ageing even if used properly. They should be checked regularly and changed after a specified working life. The applicable regulations and standards, such as DIN EN 982 "Safety Requirements for Fluid Power Systems and their Components" contain further directions.

Determining the nominal hose diameter

By means of the flow speed **V** and the volume flow **Q**, the required minimum nominal hose diameter can be calculated.

Minimum nominal hose diameter

$$d_{\min} [\text{mm}] = \sqrt{\frac{Q [\text{cm}^3/\text{s}] \cdot 4}{v [\text{m/s}] \cdot \pi}}$$

For the flow rate **Q** in l/min and the flow speed **v** in m/s, a minimum nominal hose diameter in mm can also be read from the following nomogram.

5. General data and instructions

5.1 How much oil leakage occurs with hydraulic cylinders?

With ROEMHELD hydraulic cylinders, sealing systems for the piston rod are used, generally consisting of several sealing elements. Those sealing systems enable the sealing points to be absolutely leak-proof in the total specified pressure area, when the system is not in operation. Neither does oil escape at the piston rod, nor is oil transferred from the piston side and piston rod side.

Important!

ROEMHELD hydraulic cylinders do not leak oil when static.

To ensure an adequate working life, the sealing systems must be lubricated by the hydraulic fluid while in motion, in dynamic operation. Since the hydraulic fluid must reach the seals, a certain amount of oil is lost from leaks, in the process. This quantity is, indeed, relatively small, but the leaking oil which escapes from the cylinder at the piston rod must be considered from an environmental protection point of view. If necessary, an environmentally friendly hydraulic fluid should be chosen.



The occurrence of an oil leak depends on many factors, e.g.:

- the diameter of the piston or piston rod
- the stroke
- the piston speed
- the operating pressure
- the viscosity of the hydraulic fluid
- the sealing system
- the piston rod surface

Approximate values for the dynamic occurrence of oil leaks are:

**Hydro-cylinders (B 1.282),
Hydraulic block cylinders (B 1.590)**

| Leakage rate | Piston rod Ø | |
|--|------------------------|------------------------|
| | to 32 mm | from 40 mm |
| per 1000 double strokes and 100 mm stroke (HLP 46) | < 0.35 cm ³ | < 0.70 cm ³ |

**Other hydraulic cylinders
(B 1.309 to B 1.7385)**

| Leakage rate | Piston rod Ø | |
|---|------------------------|------------------------|
| | to 32 mm | from 40 mm |
| per 1000 double strokes and 10 mm stroke (HLP 22) | < 0.30 cm ³ | < 0.60 cm ³ |

To reduce the leakage rate in the low-pressure area, hydraulic cylinders can be fitted with seal with very little leakage. Please contact us.

5.2 How great are the dimensional tolerances, when there is nothing listed on the data sheet?

What is the dimensional tolerance of the housings?

Dimensions without tolerance data correspond to the general tolerances in accordance with DIN ISO 2768 -mH.

Thus the following length and angle dimensions apply, as well as form and position tolerances.

| Length dimensions | Dimensions in mm for nominal measurement range in mm | | | | | | |
|-------------------|--|-------------|--------------|----------------|-----------------|------------------|-------------------|
| | over 0,5 to 3 | over 3 to 6 | over 6 to 30 | over 30 to 120 | over 120 to 400 | over 400 to 1000 | over 1000 to 2000 |
| m (centre) | ± 0,1 | ± 0,1 | ± 0,2 | ± 0,3 | ± 0,5 | ± 0,8 | ± 1,2 |

| Angle dimensions | Dimensions in angle units for nominal measurement range of the shorter side in mm | | | | |
|------------------|---|---------------|----------------|-----------------|----------|
| | over 10 to 10 | over 10 to 50 | over 50 to 120 | over 120 to 400 | over 400 |
| m (centre) | ± 1° | ± 30' | ± 20' | ± 10' | ± 5' |

| Evenness and Straightness | General tolerance in mm for nominal measurement range in mm | | | | | |
|---------------------------|---|---------------|----------------|-----------------|------------------|-------------------|
| | over 10 to 10 | over 10 to 30 | over 30 to 100 | over 100 to 300 | over 300 to 1000 | over 1000 to 3000 |
| H | 0,02 | 0,05 | 0,1 | 0,2 | 0,3 | 0,4 |

| Radial true run and axial true run | General tolerance in mm | |
|------------------------------------|-------------------------|-----|
| | Degree of accuracy | |
| H | | 0,1 |

Deviating from this, the following apply:

- for cast parts: General tolerance GTB 16 as per DIN 1686
- for forgings: Forging quality F as per DIN 7526

The tolerance of the stroke - unless otherwise stated - amounts to **± 1.0 mm**

The tolerance of the total length l - unless otherwise stated - amounts to **± 1.0 mm**

Those tolerances are relatively large, as they concern lengths which are made up of several components and their tolerances.

Tolerance of the housing length for block cylinders

For block cylinders, we calculate the housing length **A** from the following measurement data in the catalogue: **A = l - c**

The tolerance of the housing length does not amount to ± 1.0 mm (corresponding to the tolerance of the total length l) but is considerably smaller, as the following chart shows.

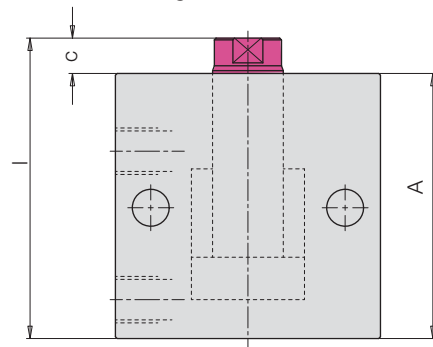

| Piston Ø [mm] | Types: | Hydraulic connection | Tolerance in [mm] for housing length A = l - c for stroke | |
|---------------|------------------------------|---|---|---------------------------|
| | | | ≤ 100 mm | >100 mm |
| Ø16 to Ø100 | 1541 to 1549 1511 to 1519 | Tube threads, Flange K and L Flange B and S | +0.3 +0.3 +0.3/-0.5 | ±0.2 ±0.2 +0.3/-0.5 |
| Ø125 and Ø160 | 1550 and 1551 | Tube threads, Flange K and L Flange B and S | ±0.2 ±0.2 ±0.2 | ±0.2 ±0.2 ±0.2 |
| Ø200 | 1552 | Tube threads, Flange K and L Flange B and S | ± 0.3 ± 0.3 ± 0.3 | ± 0.2 ± 0.2 ± 0.2 |

5.3 What must be taken into account for safety?

- Before assembly, start-up, operation and maintenance of hydraulic cylinders, it is essential to observe the notes in the corresponding **operating instructions**.
- Always heed the **application limits** of the hydraulic cylinders. This particularly applies to the **maximum operating pressure**, but also to the **temperature, flow speed, resistance** to the hydraulic fluid etc.
- It is recommended always to install a manometer or similar **for displaying pressure** and, if necessary, suitable **safety valves for excess pressure restriction**.
- **Risk of crushing** - always keep hands and other body parts away from the working area
- Take care to ensure that the **forces** from the hydraulic cylinder **are received by** the parts to which the cylinder is fastened.
- Use only **clean hydraulic oil** in accordance with chapter 3.5.
- **Never modify** a hydraulic cylinder or an accessory **yourself** (e.g. adding holes, milling, etc.). Please contact us, if any modifications are necessary.



5.4 What support can I get for assembly, start-up, maintenance and repairs?

Notes on assembly, start-up and maintenance of hydraulic cylinders can be found in the corresponding **operating instructions**.

For repairs, **spare part lists and drawings** are available.

You can also have **repairs** done by ROEMHELD. Simply send us the faulty hydraulic cylinders. You will receive an initial quote for the repairs. After you have released them for repair, the cylinders are repaired, tested and sent back to you.

Moreover, ROEMHELD offers a **technical support service**, which also carries out all those tasks on your premises.

5.5 What do the graphic symbols in the hydraulic diagram mean?

Graphic symbols are a kind of shorthand and serve towards rapid communication between experts, transcending language barriers.

The graphic symbols for oil hydraulics and pneumatics are established at an international level in DIN ISO 1219. In the following selection, we mainly explain the graphic symbols for devices which can be found in the ROEMHELD range.

Each graphic symbol labels a device and its function but not its model.

In circuit diagrams, the devices are shown in the zero setting and, if this is not available, in the starting position for the controls, and the systems are displayed in rest position. If there is any deviation from this, a note is required, e.g. operating position.

| Designation and Explanation | Graphic Symbols |
|---|-------------------------|
| Pressure source | |
| Connection to hydraulic or pneumatic energy source | |
| Electric motor | |
| With almost constant speed and specified direction of rotation | |
| Tubes | |
| Control line, return line, energy transfer line | |
| Regulation line | |
| Line for transferring regulating energy, including setting and regulation | |
| Leakage line | |
| Outlet line for any leaking fluid or for bleeding | |
| Flexible tubing | |
| Rubber hose, mainly connected to moving components | |
| Electrical wiring | |
| Seldom drawn on the hydraulic circuit diagram | |
| Marking | 8 x 1.5 DIN 2391 NBK |
| Tubing dimensions can be entered in DIN short description above the line | |
| Tube connection | |
| Tight connection, e.g., screwed in, including fittings | |
| Crossing | |
| Crossing of tubes which are not interconnected | |
| Bleed points | |
| Pressure connection point | |
| Pressure connection to equipment and tubes for extracting energy or for measurements with drain plugs | |
| Quick couplings | |
| Tube connection which can be produced and separated off without tools by mechanically opened shut-off valves | |
| Uncoupled, tube closed by shut-off valve | |
| Rotary union | |
| Tube connection rotating in operation. e.g., in two directions (twin passage) | |
| Reservoir with tubes below the liquid level | |
| Hydraulic accumulator | |
| Device for storing hydraulic energy. The liquid is pressurised by a gas (nitrogen). The energy is released by the pressurised flow of liquid. | |
| Filter | |
| Machine for separating dirt particles | |
| Fixed displacement pump | |
| Hydraulic pump with almost constant displacement per stroke with 1 conveying direction | |
| with 2 conveying directions | |
| Variable displacement pumps | |
| Hydraulic pump with adjustable displacement volume per stroke | |

| Designation and Explanation | Graphic Symbols |
|--|----------------------------|
| Cylinders | |
| Device working in straight line for converting hydraulic or pneumatic energy to mechanical energy | |
| Single-acting cylinders | |
| The force exerted by the pressurising medium moves the piston in only 1 direction | |
| displacement by external force | |
| displacement by installed return springs | |
| Double-acting cylinders | |
| The force exerted by the pressurising medium moves the pistons in 2 directions | |
| with piston rod on one side | |
| with piston rods on both sides | |
| Cylinders with cushioning | |
| Double-acting cylinder with non-adjustable cushioning on both sides | |
| Intensifier | |
| Device consisting of 2 different x and y pressure chambers for increasing pressure, air or the liquid in y | |
| | e.g., air to hydraulic oil |
| Directional valves | |
| Valves which affect the direction of a hydraulic flow (mainly start, stop, direction of flow) | |
| Switch positions | |
| The switch positions are marked with Arabic numerals. For valves with previous resetting, e.g., spring, the switch position which is accepted by the moving parts of the valve, when the valve is not connected, is referred to as the zero setting. | |
| Connections | |
| The connections (in and outflows) are drawn towards the zero position field and labelled in capital letters: | |
| e.g. Control connections | A, B, C... |
| inflow, pressure (pump) | P |
| outflow, return flow, reservoir | R, S, T |
| oil leakage | L |
| regulation lines | Z, Y, X... |
| Tubes and direction of flow | |
| Lines indicate the tubes and arrows the direction of flow inside the fields. | |
| Shut-off devices are shown by crosses inside the fields | |
| Activating valves | |
| e.g., by activating the electromagnet and return spring | |
| Short description | |
| The number of controlled connections and switch positions is placed in front of the designation direction valve | |
| e.g., 3/2 directional control valves | |
| (3 controlled connections, P, A, R, and 2 switch positions, 0 and 1) | |
| 2/2 directional control valves | |
| a) with stop in zero position | |
| b) with flow in zero position | |
| 3/2 directional control valves | |
| a) In zero position, the user is connected to the pump | |
| b) In zero position, the user is connected without pressure to the return flow | |
| 4/2 directional control valves | |
| For steering double-acting cylinders into the stop positions (with no intermediate position) | |
| 4/3 directional control valves | |
| a) all connections blocked in zero position. For steering double-acting cylinders with any stop | |
| b) Control connections A and B connected to the return flow in the zero position (floating position) | |
| b) With zero rotation position and blocked A and B control connections | |
| Non-return valves | |
| Valves which block the flow in a preferred direction and release it in the opposite direction. The pressure on the outflow side stresses the stopping part and thus helps the valve to close. | |
| Check valve | |
| Non-return valve which closes by means of force exerted on the closing part | |
| Sealing, when outlet pressure is greater than inlet pressure | |
| Pilot-operated check valve | |
| Check, the sealing action of which can be overridden by being hydraulically activated | |
| Flow control valve | |
| Throttle valve with flow in one direction and adjustable throttling in the other | |
| Pressure valves | |
| Valves, which mainly influence the pressure. | |
| Shown with only one field and always in zero position | |
| Pressure relief valve | |
| Valve to relieve the pressure at the inlet by opening the outlet with restoring force | |
| Opening pressure adjustable | |
| Explanation | |
| If the inlet pressure is lower than the set spring pressure, the valve remains closed. | |
| If the inlet pressure exceeds the spring pressure, the valve opens (arrowhead is pushed into flow position) | |



| Designation and Explanation | Graphic Symbols |
|---|-----------------|
| Sequence valve Valve which gives access to other devices by opening the outlet on spring pressure | |
| Sequence valve with fitted check valve. Enables free return flow | |
| Pressure reducing valve Valve which keeps the outlet pressure constant to a major extent, even if the inlet pressure is modified but higher. | |
| Pressure reducing valve with fitted non-return valve Enables return flow. | |
| Flow control valves Valves which mainly affect the flow. | |
| Throttle valve Flow control valve with constant tube-installed reduction. Flow and drop in pressure depend on viscosity | |
| Throttle valve, adjustable | |
| Non-return throttle valve Throttle valve with flow in one direction and adjustable throttling in the other | |
| Flow control valves Flow control valve which keeps the set flow almost constant, irrespective of pressure deviations in the inlet or outlet and when deviations in viscosity occur | |
| Flow control valve with fitted check valve Enables unthrottled return flow | |
| Shut-off valve Simplified display | |
| Operational modes | |
| Mechanical elements | |
| Means of activation The symbols for the means of operation of a machine are added to the symbol of the machine in question | |
| Muscle-power operation generally | |
| by button | |
| by lever | |
| by pedal | |
| Example: foot-operated displacement pump with 1 conveying direction | |
| Mechanical operation | |
| by button | |
| by spring | |
| by follower roll | |
| Electrical operation by electromagnet | |
| Pressure operation direct admission by pressure admission | |
| indirect operation by pressure admission of the servo control valve | |
| Measuring units | |
| Pressure gauge | |
| Pressure switch Device, which contains electrical contacts and which can be closed or opened with pressure. The switching pressure is adjustable | |

6. Special requirements

6.1 Are lateral piston forces admissible or are there special designs?

Normal hydraulic cylinders are only suitable to a limited degree for absorbing transverse forces to the piston rod and the resulting torque stresses.

Constant transverse force and stress to piston guides

Piston retracted

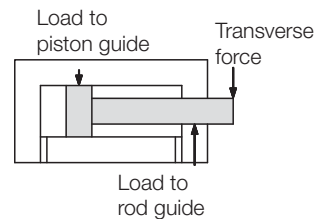

Pistons extended

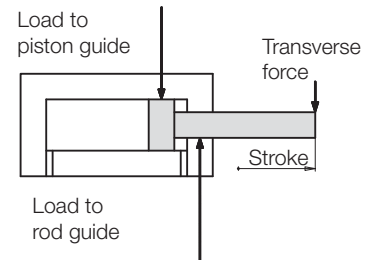

Transverse forces stress the guides for the piston and piston rod of the cylinder and thereby cause a reduction in working life and leakage leading to the destruction of the cylinder. For this reason, transverse forces should be avoided - especially with single-acting cylinders.

Under no circumstances must the cylinder transverse force exceed 3% of the cylinder force at maximal operating pressure (up to stroke of 50 mm). With longer strokes this becomes more and more critical.

ROEMHELD supplies the following special series for absorbing transverse piston forces and torque stresses:

RS hydraulic slides (B 1.7385)

Hydraulic block cylinder with 4 guiding columns fitted to the side for high transverse forces. A front block is assembled on the guiding columns and the piston rod, to which working loads, e.g. tools, can be attached.

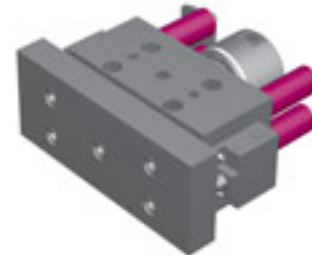

Data sheet B 1.7385 contains data on the maximal permitted working loads, as well as graphics of the maximal permitted torques produced by the transverse forces.

RM mini slides (B 1.7384)

Hydraulic slide on block cylinder base. The RM slide also has 4 guiding columns which are connected to a front block, which, however, is of a much smaller design than that for the RS slide.

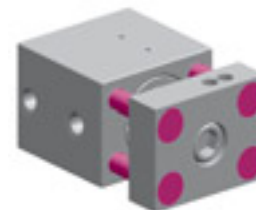

That is why the RM mini slide is more suited to weak to medium transverse force loads.

You will find more detailed information on the data sheet.



Polygon cylinders (B 1.560)

Block cylinder with aluminium housing and with a piston rod with polygon shape, which prevents it from torsion. Absorption of the transverse forces is accomplished by means of long guide bushing.

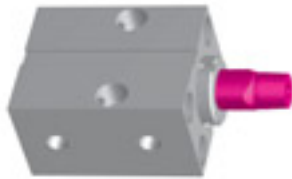

Block cylinder with guide housing (B 1.738)

Block cylinder of aluminium or steel with prefabricated guide housing, in which a pin is supported. The pin is positively fitted to the piston rod and transfers the hydraulic force to the point of application. All transverse forces which occur are transferred only to the pin, i.e. the guide housing.

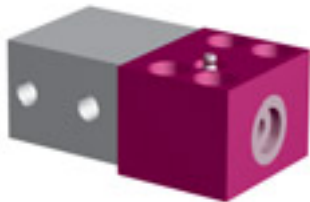

Hydraulic block cylinders (B 1.590) and hydro-cylinders (B 1.282)

Hydraulic cylinders in cylinder tube design for strokes up to 1200 mm. By means of a special guide system, transverse forces can even be absorbed in the case of longer strokes.



0°- swing clamps

ROEMHELD swing clamps, which are mainly used in the fixture construction, can also be supplied as standard with 0° angle of rotation, meaning no swing motion.

Since the swing clamp is designed to absorb higher clamping torques, with this modification it can be used as a linear cylinder for transverse forces.

You will find 0° swing clamps in numerous series, in the ROEMHELD Power Workholding Catalogue.



6.2 Which anti-torsion device designs exist?

Traditional hydraulic cylinders do not have an anti-torsion device; the piston system can simply become twisted by the cylinder housing. Although this does not affect the cylinder functioning, it can be undesirable for the application.

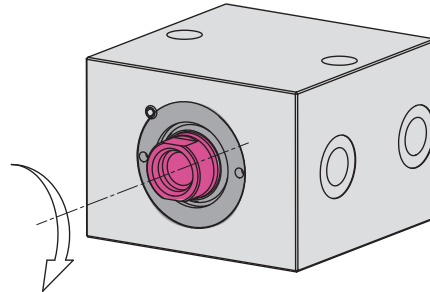

In addition to the possibility of connecting an external anti-torsion device to the piston rod, the following designs for hydraulic cylinders are available with built-in anti-torsion. In making your choice, it is particularly important to consider the radial play of the anti-torsion device.

RS hydraulic slides (B 1.7385)

Hydraulic block cylinder with 4 guiding columns fitted to the side. A front block is assembled on the guiding columns and the piston rod, to which working loads, such as tools, can be attached. This guarantees anti-torsion which is free from play.

The permitted torques are listed on the data sheet.



RM mini slides (B 1.7384)

Hydraulic slide on block cylinder base. The RM slide also has 4 guiding panels which are connected to a front block, which, however, is of a much smaller design than that for the RS slide.

That is why the RM mini slide is more suited to weak to medium torques.



Polygon cylinders (B 1.560)

Block cylinder with aluminium housing and with a piston rod with polygon shape, which prevents it from torsion. The radial play amounts to ± 0.3 degrees.

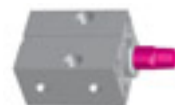

0°- swing clamps

ROEMHELD swing clamps with 0° angle or rotation can be used as linear cylinders (see 6.1).

Since the piston of the swing clamp is kept in a slot, it is prevented from torsion.

Depending on the version, the radial play is 2 degrees maximum.

You will find 0° swing clamps in numerous series, in the ROEMHELD Power Workholding Catalogue.





6.3 Which versions are available with stroke end cushioning?

If hydraulic cylinders are operated at high speeds, when the piston hits the stroke end position unimpeded, a high amount of energy is released and must be absorbed by the cylinder housing and the threaded bushing.

This can lead to a reduction in the cylinder's working life. This can also result in undesirable effects on the actual function, caused by shaking and noise coming from the knocking.

Reducing the speed helps, of course. If this is not possible, however, it is recommended that a cylinder with integrated hydraulic stroke end cushioning be used.

In the last few millimetres of the stroke (e.g. 8 mm), this stroke end cushioning forces the hydraulic fluid through a hole or similar. By means of this deflection, the flow rate is choked and the piston speed and the energy in the end positions is thus reduced.

If you are considering choosing a hydraulic cylinder with end cushioning, you must consider the following:

- The shorter the stroke, the more logical it can be to generally reduce the speed
- Stroke end cushioning, adjustable on the cylinder, is ideal, as the cushioning effect can be adjusted to the particular use. In addition, both end positions can be separately adjusted.
- If the cylinder is impelled against a fixed external stop, the cylinder housing and the threaded bushing are not themselves stressed. Stroke end cushioning to protect the cylinder is not necessary in that case.

ROEMHELD supplies the following hydraulic cylinders with stroke end cushioning:

- B 1.282 - Hydro-cylinders (adjustable stroke end cushioning)
- B 1.530 - Block cylinders (adjustable stroke end cushioning)
- B 1.590 - Hydraulic block cylinders (adjustable stroke end cushioning)
- B 1.7385 - RS hydraulic slides (non-adjustable stroke end cushioning)

6.4 What possibilities exist for checking the piston position?

To check the piston position of hydraulic cylinders, position controls or position monitoring components, are used. For each position to be checked, one sensor is required. Sensors or position controls are always considered as accessories or options. That means that they do not form part of the hydraulic cylinder delivery scope and must be ordered as separate items. The sensors are frequently connected to two plugs with fitted cables, which have an LED function display.

The following sensors are differentiated:

Magnetic sensors

A permanent magnet is fixed to the piston, and its magnetic field is detected by a magnetic electronic sensor. With block cylinders, the magnetic sensors are fixed to the outside of the housing in slots running lengthwise.

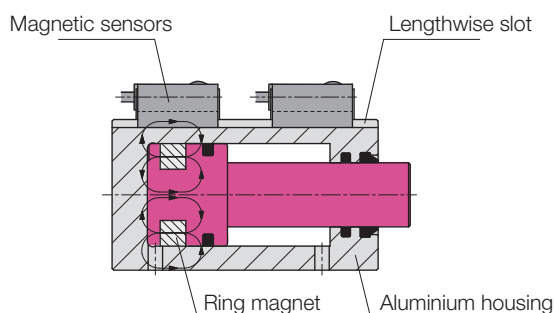

Advantages of using magnetic sensors are:

- Compact design / minimum space requirement
- Switching points adjustable by moving the sensors along the lengthwise slots
- Possibility of checking several positions, as several sensors can be attached in the two lengthwise slots of the housing, irrespective of the length of the slot or the stroke. In one slot, the minimum distance between the switching points is 6 mm; with two slots it is 3 mm.

While using magnetic sensors, you must heed the following:

- Magnetic sensor checks can only be used with housings which cannot be magnetised (aluminium or bronze).

At maximum operating pressure, ROEMHELD aluminium housings are restricted to 350 bar and are not suited to abrupt stresses, which occur, for example, with punching and cutting processes. For such applications up to 500 bar max., ROEMHELD supplies block cylinders with bronze housings.

- Influencing the magnetic field with adjacent, magnetisable parts (e.g. steel parts):

In order to guarantee perfect functioning, it is recommended that a distance of at least 25 to 30 mm be maintained between magnetic sensor and magnetisable parts. The function is indeed possible with a smaller distance but this depends highly on the individual circumstances for fitting. Thus ordinary steel bolts can also normally be used for fastening the cylinder. In borderline cases, screws of non-magnetisable steel (e.g. VA screws) can cause an improvement in the magnetic field.

- Influencing the magnetic field with adjacent magnetic sensors

If several block cylinders with magnetic sensors are installed directly adjacent to one another, the magnetic sensors can have a reciprocal influence and malfunctions occur. A magnetisable steel sheet can help, placed between the block cylinders, i.e. magnetic sensors, as a shield.

- Requirements of the voltage supply

See data sheet G 2.140 - Magnetic sensors for position monitoring

- Maximum operating temperature for all required components

- Magnet: +100 °C
- Magnetic sensor: +100 °C
- Connecting cable with right angle plug: +90 °C

- Path and switching hysteresis of approx. 3 mm

This must be heeded as early as the adjustment stage of the magnetic sensors. For static pistons, the magnetic sensor must always be pushed forward to the piston from the opposite direction.

You will find more detailed information on the use of magnetic sensors in the following texts:

G 2.140 - Magnetic sensors for position monitoring

From the User - For the User 118: Use of magnetic sensors for position monitoring of hydro-cylinders



ROEMHELD supplies the following hydraulic cylinders with magnetic sensors:

- B 1.553 - Block cylinders with bronze housing
- B 1.554 - Block cylinders with aluminium housing
- B 1.560 - Block cylinders with aluminium housing, with anti-rotation piston
- B 1.738 - Block cylinders with guide housing, version with block cylinders with aluminium housing

Inductive proximity sensors

There are two models of position controls with inductive proximity sensors.

Check with high-pressure resistant proximity initiators for the end position control.

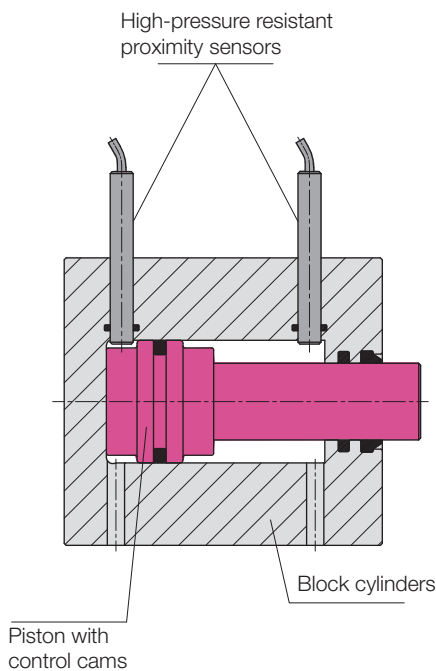

For every end position, the cylinder housing is given a hole with interior thread, into which a high-pressure resistant, interactive proximity sensor can be screwed. The sensor checks the piston of the cylinder directly. It is sealed on the outside with an O-ring. By means of the switching distance between the sensor and the piston, the switching point can be adjusted to 5 mm before the end position.

Only the end positions of the hydraulic cylinder are checked by the high-pressure resistant sensors. The maximum operating temperature of the sensors is 80 °C or 120 °C.

ROEMHELD supplies the following hydraulic cylinders with high-pressure resistant proximity initiators:

- B 1.520 - Block cylinders for stroke end control
- B 1.530 - Block cylinders for stroke end control and stroke end cushioning
- B 1.590 - Hydraulic block cylinders

Check with commercially available proximity initiators

For a check with commercially available proximity initiators, block cylinders are equipped with a piston rod which passes through the cylinder base. In addition a housing for checking, in which the sensors are adjustably fitted, is flanged on the cylinder base. The sensors are energised by control cams on the piston rod.

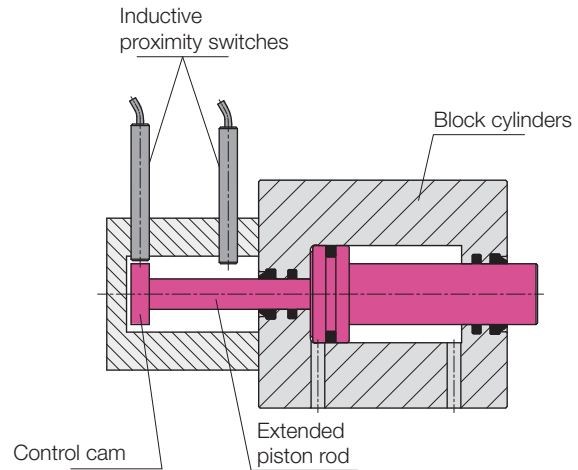

The additional housing makes the total length considerably longer but commercially available sensors with M8 x 1 external threads can be used. Because the sensors can be moved, intermediate positions can also be checked.

The maximum operating temperature of the sensors is 70°C. The "Type C - high ambient temperature" version, including the Teflon connector cable, is suitable for temperatures up to 120°C.

Proximity initiators for temperatures up to 180°C are already being supplied by various manufacturers, but take up considerably more space than the M8 versions.

ROEMHELD supplies the following hydraulic cylinders with commercially available inductive proximity initiators:

- B 1.552 - Block cylinders with extended piston rod for position monitoring
- B 1.738 - Block cylinders with guide housing
- B 1.7384 - RM mini slides

Mechanical limit switch

For RM mini slides and RS hydraulic slides, mechanical limit switches are offered as an option. The switches are accommodated in an aluminium housing, which makes them especially suitable for robust applications. The maximum operating temperature of the switches is 70 °C.

The RM mini slide can be optionally equipped with one or two switch rods, on which adjustable control cams activate the limit switches.

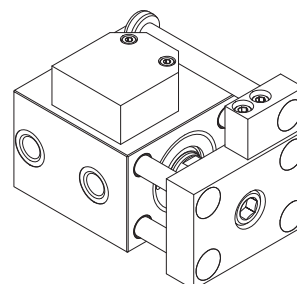



With the RS hydraulic slide, a switch is activated from the front block (retracted) and a switch is activated from the control vane on the guiding columns (extended).

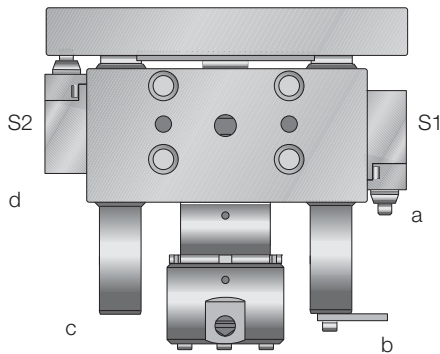

- a S1 limit switch (extended)
- b control vane
- c guiding columns
- d S2 limit switch (retracted)

Through adjusted fastening angles it is also possible to use your own limit switches or proximity initiators.

The maximum operating temperature of the switches is +70 °C.

Mechanical limit switches are also available for temperatures well over 100 °C, from various manufacturers.

6.5 Which accessory parts does ROEMHELD have in the range?

Apart from the range of hydraulic cylinders, ROEMHELD also offers a wide range of accessory parts. The appropriate data sheets are in the "Accessories" section of this catalogue.

They comprise the areas of:

- Hydraulic valves : C 2.940 to C 2.954
- Intensifiers : D 8.753 and D 8.756
- Tubes and fittings,
- Hydraulic oil, pressure gauges : F 9.300
- Tube clamps : F 9.310
- High-pressure hydraulic hoses : F 9.361
- Quick-disconnect couplings : F 9.381
- High-pressure filters : F 9.500
- Magnetic sensors : G 2.140
- Contact bolts : G 3.800
- Spherical Bearings : G 3.810

6.6 What are the supply possibilities for stroke lengths not listed in the catalogue?

ROEMHELD hydraulic cylinders are offered in the catalogue in two different stroke categories, dependent on the type.

Standard strokes:

For block, universal and threaded-body cylinders

For those cylinders, stroke lengths of approx. 16 mm to a maximum of 200 mm are supplied in fixed categories (e.g. 25, 50, 100, 160 and 200 mm). Strokes over 200 mm (approximate value, dependent on the diameter) are not usually a possibility, since the internal machining of the cylinder hole limits the maximum stroke possible.

Stroke classification in mm:

With hydro-cylinders B 1.282, hydraulic block cylinders B 1.590 (as a variant also with RS hydraulic slides B 1.7385)

With those cylinders, it is relatively easy to manufacture individual and very long strokes, because only the length-dependent components, such as piston rod and cylinder tube, have to be adjusted.

The design demands a specified minimum stroke to be necessary.

Stroke lengths not listed in the catalogue can, of course, also be supplied - within manufacturing limitations. There are two possibilities here:

Inserting a distance bushing: Economical and quickly supplied intermediate strokes

A distance bushing is inserted on the piston rod side in the standard cylinder with the next largest stroke and fastened inside the housing. That means the piston can no longer complete the extending stroke and the stroke is restricted by this internal stop, dependent on the length of the bushing.

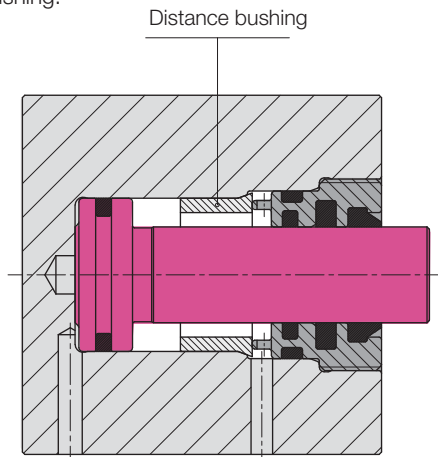

Since the distance bushing must be a specific minimum length, the following approximate values apply to the strokes available:

For data sheet B 1.5094, B 1.542, B 1.554

Maximum strokes possible from inserting a distance bushing

| Piston diameter | Maximum stroke possible |
|--------------------|-------------------------|
| to 40 mm | Standard stroke -3 mm |
| over 40 to 63 mm | Standard stroke -4 mm |
| over 63 to 100 mm | Standard stroke -6 mm |
| over 100 to 200 mm | Standard stroke -8 mm |

Example: Block cylinder 1545-165

Standard stroke 50 mm, max.stroke possible = 50 mm-4 mm = 46 mm

With some block cylinders, the distance bushing is fastened to the piston rod by shrink fitting.

For data sheet B1.520

Maximum/minimum strokes possible from shrink-fitting a distance bushing

| Block cylinders | Max. stroke possible | Min. stroke |
|-----------------|-----------------------|-------------|
| 1531-XXX-H | Standard stroke -3 mm | 5 mm |
| 1533-XXX-H | Standard stroke -4 mm | 5 mm |
| 1534-XXX-H | Standard stroke -5 mm | 5 mm |
| 1535-XXX-H | Standard stroke -5 mm | 5 mm |
| 1536-XXX-H | Standard stroke -6 mm | 5 mm |
| 1537-XXX-H | Standard stroke -6 mm | 5 mm |
| 1538-XXX-H | Standard stroke -7 mm | 5 mm |
| 1539-XXX-H | Standard stroke -7 mm | 5 mm |

Example: Block cylinder 1535-166

standard stroke 50mm, max. stroke possible = 50mm -5 = 45mm

The stroke limitation with distance bushing on the piston rod side is available as a cylinder variant with a supplementary price on the standard cylinder (see current price list). The stroke limitation with distance bushing on the piston rod side is a special design because of the fixing and has to be specially requested.



Special cylinders: Manufacture dependent on quantities

Of course, ROEMHELD also supply cylinders with housing and piston specially designed for a stroke which is not listed in the catalogue. These versions are special versions which are usually only manufactured in quantities related to orders.

6.7 The required hydraulic cylinder is not listed in the catalogue - are special cylinders available?

In addition to a wide catalogue range of hydraulic cylinders and accessories, ROEMHELD also supplies variants of the catalogue versions. Moreover, ROEMHELD also supplies hydraulic cylinders which are designed and manufactured according to individual customer requirements. Please contact us.

In the case of special cylinders, after technical clearance you receive from us an installation drawing of the cylinder, which contains all dimensions necessary for the installation.

7. Further Information

7.1 How do I get CAD data for the hydraulic cylinder? Which CAD formats are available?

ROEMHELD provides CAD data of hydraulic cylinders in the following formats, to integrate in your own designs:

- 2D format: - dxf
- 3D formats: - STEP (.stp)
- PARASOLID (.x_t)
- ACIS (.sat)
- CATIA Export (.exp)
- CATIA Model (.model)

The CAD data concern the shell or outer contours of catalogue versions.

The 3D data for hydraulic cylinders are usually constructed in two parts. Since housing and piston are two distinct elements, the piston can be shown in any desired stroke position.

The CAD data are available in the GEOLIB-3D database on DVD (RIC - ROEMHELD Interactive Catalogue) and on www.roemheld.de on the Internet.

To gain access to the CAD data and to be able to download them, your registration with ROEMHELD is required (e.g. online or by phone).

When registration is confirmed, you receive an activation code for the RIC. After inputting this code and your customer number under "Configuration", you are granted access.

No registration key is required to access the Internet. Access is generated on the Internet, after receipt of the registration confirmation and log-in details.

Any search for CAD data and any file download must always be performed using the item number.

Download from DVD is only possible via the installed RIC. Direct download, e.g. via Windows Explorer, is not possible.

Since the CAD data are constantly being supplemented on the Internet and since the RIC appears annually, data or cylinders which are not on the current RIC occasionally appear on the Internet.

We shall be glad to answer any questions on the RIC and on CAD data on our

RIC Hotline: Phone: +49(0)6405 / 89-456
E-mail: ric-hotline@roemheld.de

7.2 Who can answer any other questions?

Our sales partners are available to answer any questions in-house and in the field.

Employees of our in-house "Technical" service will answer your questions connected with applications and provide detailed information on the ROEMHELD catalogue or special cylinders and accessory parts, whereas our in-house "Sales" employees will deal competently with your business and order-processing queries.

You will find all the contact persons you require, with phone and fax number as well as e-mail address, in our information sheet "Sales Partners in Germany and Worldwide" in this catalogue.

7.3 Do I have the latest edition of a catalogue sheet?

This catalogue is in the form of a ring file, to enable data sheets on newly developed hydraulic cylinders to be added easily. Data sheets are also reprinted if a typing error is discovered at a later stage or if a product has been revised.

If you are not sure if the current data sheet is available, it is helpful to check on the Internet on www.roemheld.com, where the latest edition of all data sheets is always available in PDF format. (The issue date of a data sheet is in the upper right-hand corner of the first page, above the data sheet number). Or contact your local sales partner.